

RoHS Compliant
Industrial Secure Digital Card
Product Specifications

March 2, 2022

Version 1.2



Apacer Technology Inc.

1F, No.32, Zhongcheng Rd., Tucheng Dist., New Taipei City, Taiwan, R.O.C

Tel: +886-2-2267-8000 Fax: +886-2-2267-2261

www.apacer.com

Specifications Overview:

- **Fully compatible with SD card standard specification**
 - SD Memory Card Specifications, Part 1, Physical Layer Specification, Version 2.00
 - SD Memory Card Specifications, Part 2, File System Specification, Version 2.00
 - SD Memory Card Specifications, Part 3, Security Specification, Version 2.00
- **Capacity**
 - Standard: 256, 512 MB
1, 2 GB
 - SDHC: 4, 8, 16, 32 GB
- **Performance¹**
 - Sequential read: Up to 23 MB/sec
 - Sequential write: Up to 17 MB/sec
- **Flash Management**
 - Built-in hardware ECC
 - Global Wear Leveling
 - Flash bad-block management
 - S.M.A.R.T.
- **NAND Flash Type: SLC**
- **Endurance (in Terabytes Written: TBW)**
 - 256 MB: 3 TBW
 - 512 MB: 6 TBW
 - 1 GB: 12 TBW
 - 2 GB: 24 TBW
 - 4 GB: 49 TBW
 - 8 GB: 98 TBW
 - 16 GB: 196 TBW
 - 32 GB: 383 TBW
- **Temperature Range**
 - Operating:
 - Standard: 0°C to 70°C
 - Wide: -40°C to 85°C
 - Storage: -40°C to 100°C
- **Supply Voltage**
 - 2.7V ~ 3.6V
- **Power Consumption¹**
 - Standby: 110 μA
 - Read: 45 mA
 - Write: 55 mA
- **SD-Protocol Compatible**
- **Supports SPI Mode**
- **Variable Clock Rate 0-50MHz**
- **Intelligent Endurance Design**
- **Physical Dimensions**
 - 24.00 x 32.00 x 2.10, unit: mm
- **RoHS Compliant**

Note:

1. Varies from capacities. The values for performances and power consumptions presented are typical and may vary depending on flash configurations or platform settings. The term idle refers to the standby state of the device.

Table of Contents

1. General Description	3
1.1 Functional Block.....	3
1.2 Functional Descriptions.....	4
1.2.1 Flash Management	4
1.2.2 Powerful ECC Algorithms	4
1.2.3 Power Management.....	4
1.2.4 S.M.A.R.T	4
2. Electrical Characteristics	5
2.1 Card Architecture	5
2.2 Pin Assignment	5
2.3 Capacity.....	6
2.4 Performance.....	6
2.5 Endurance	7
2.6 DC Power Supply.....	7
2.7 Power Consumption.....	7
3. Physical Characteristics.....	8
3.1 Physical Dimensions.....	8
3.2 Durability Specifications.....	10
4. DC Characteristics	11
4.1 SD Interface Timing (Default)	11
4.2 SD Interface Timing (High Speed Mode).....	12
4.3 SD Interface Timing (SDR12, SDR25, SDR50 and SDR104 Modes) Input.....	14
4.3.1 Clock Timing	14
4.3.2 Card Input Timing	14
4.3.3 Card Output Timing of Fixed Data Window (SDR12, SDR25 and SDR50)	15
4.3.4 Output Timing of Variable Window (SDR104)	15
4.3.5 SD Interface Timing (DDR50 Mode).....	16
4.3.6 Bus Timings – Parameters Values (DDR50 Mode).....	17
5. Product Ordering Information.....	18
5.1 Product Code Designations	18
5.2 Valid Combinations	19

1. General Description

As the demand of reliable and high-performance data storage in a small form factor increases, Apacer's embedded SD card is designed specifically for rigorous applications by offering maximum endurance, reliability, and agility, where extreme traceability, enhanced data integrity, and exceptionally velocity are required.

1.1 Functional Block

The embedded SD contains a flash controller and flash media with SD standard interface.

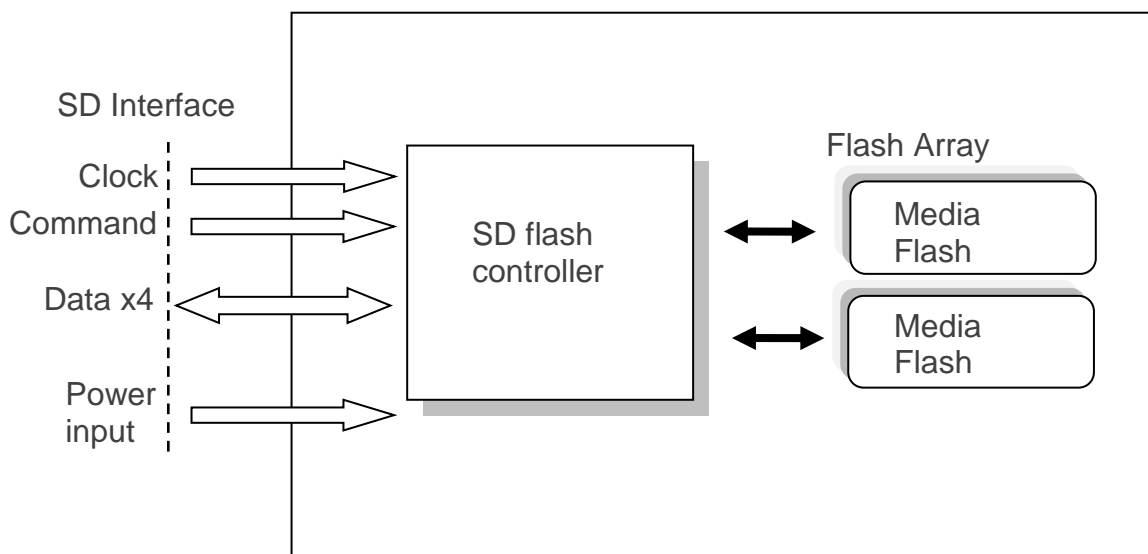

Figure 1-1 Functional Block Diagram

1.2 Functional Descriptions

1.2.1 Flash Management

The SD controller contains logic/physical flash block mapping and bad block management system. It will manage all flash block include user data space and spare block.

The embedded SD also contains a sophisticated defect and error management system. It does a read after write under margin conditions to verify that the data is written correctly (except in the case of write pre-erased sectors). In case that a bit is found to be defective, the embedded SD replaces this bad bit with a spare bit within the sector header. If necessary, the embedded SD will even replace the entire sector with a spare sector. This is completely transparent to the master (host device) and does not consume any user data space.

1.2.2 Powerful ECC Algorithms

The powerful ECC algorithms will enhance flash block use rate and whole device life. The SD controller has an innovative algorithm to recover the data. Built-in BCH-ECC supports correction up to 24 bits data error per 1K bytes data automatically

1.2.3 Power Management

A power saving feature of the embedded SD is automatic entrance and exit from sleep mode. Upon completion of an operation, the embedded SD will enter the sleep mode to conserve power if no further commands are received within X seconds, where X is programmable by software. The master does not have to take any action for this to occur. The embedded SD is in sleep mode except when the host is accessing it, thus conserving power.

Any command issued by the master to the embedded SD will cause it to exit sleep mode and response to the master.

1.2.4 S.M.A.R.T

S.M.A.R.T. (SMART), an acronym stands for Self-Monitoring, Analysis and Reporting Technology, is an open standard allowing an individual disk drive in the ATA/IDE or SCSI interface to automatically monitor its own health and report potential problems in order to prevent data loss. This failure warning technology provides predictions from unscheduled downtime by observing and storing critical drive performance and calibration parameters. Ideally, this should allow taking hands-on actions to keep from impending drive failure.

Failures are divided into two categories: those that can be predicted and those that cannot. Predictable failures occur gradually over time, and the decline in performance can be detected; on the other hand, unpredictable failures happen very sudden without any warning. These failures may be caused by power surges or related to electronic components. The purpose of the SMART implementation is to predict near-term failures of each individual disk drive and generate a warning to prevent unfortunate loss.

2. Electrical Characteristics

2.1 Card Architecture

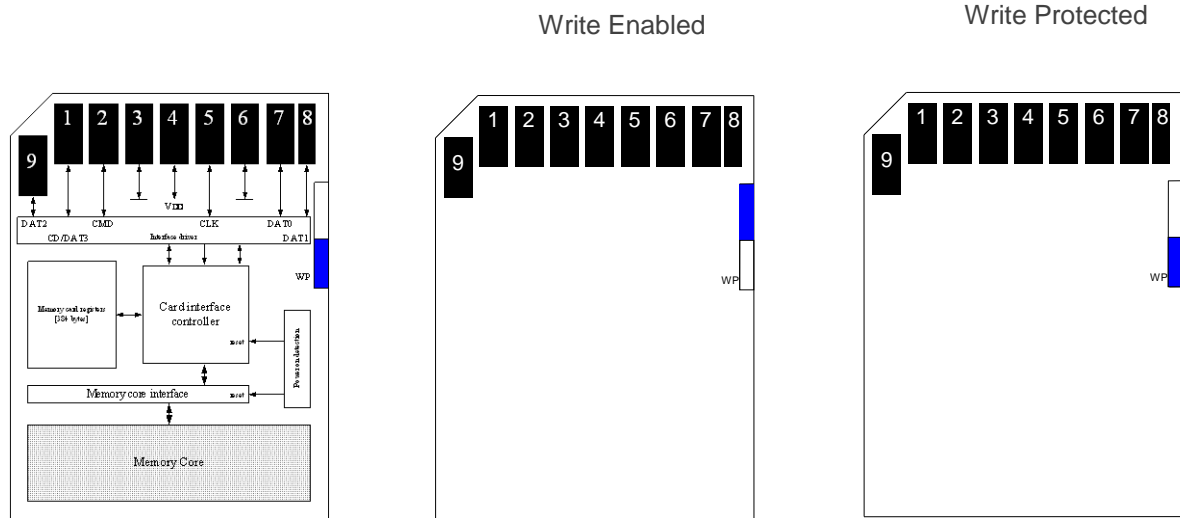

Figure 2-1 Card Architecture

2.2 Pin Assignment

Table 2-1 Pin Assignments

Pin	SD Mode		SPI Mode	
	Name	Description	Name	Description
1	CD/DAT3	Card detect/Data line[Bit 3]	CS	Chip select
2	CMD	Command/Response	DI	Data in
3	VSS1	Supply voltage ground	VSS	Supply voltage ground
4	VDD	Supply voltage	VDD	Supply voltage
5	CLK	Clock	SCLK	Clock
6	VSS2	Supply voltage ground	VSS2	Supply voltage ground
7	DAT0	Data line[Bit 0]	DO	Data out
8	DAT1	Data line[Bit 1]	Reserved	
9	DAT2	Data line[Bit 2]	Reserved	

2.3 Capacity

Capacity specifications of the SD card are available as shown in Table 2-2.

Table 2-2 Capacity Specifications

Capacity	Total (LBA) Sectors	Total Partition Sectors	User Data Sectors	User Data Bytes
256 MB	499,712	499,611	499,456	255,721,472
512 MB	985,088	984,851	984,576	504,102,912
1 GB	2,000,896	2,000,651	2,000,128	1,024,065,536
2 GB	4,009,984	4,009,739	4,009,216	2,052,718,592
4 GB	8,019,968	8,011,776	8,003,584	4,097,835,008
8 GB	16,039,936	16,031,744	16,023,552	8,204,025,856
16 GB	31,719,424	31,711,232	31,703,040	16,231,923,712
32 GB	63,438,848	63,430,656	63,414,272	32,468,074,496

Note: The statistics may vary depending on file systems of various OS. User data bytes do not indicate total useable bytes. LBA count addressed in the table above indicates total user storage capacity and will remain the same throughout the lifespan of the device. However, the total usable capacity of the SD is most likely to be less than the total physical capacity because a small portion of the capacity is reserved for device maintenance usages.

2.4 Performance

Performance of the SD card is listed below in Table 2-3.

Table 2-3 Performance Specifications

Capacity	256 MB	512 MB	1 GB	2 GB	4 GB	8 GB	16 GB	32 GB
Performance								
Sequential Read (MB/s)	22	23	23	23	23	23	23	23
Sequential Write (MB/s)	11	17	17	18	17	17	16	17

Notes:

- Results may differ from various flash configurations or host system setting.
- Sequential read/write is based on CrystalDiskMark 5.2.1 with file size 1,000MB.

2.5 Endurance

The endurance of a storage device is predicted by TeraBytes Written based on several factors related to usage, such as the amount of data written into the drive, block management conditions, and daily workload for the drive. Thus, key factors, such as Write Amplifications and the number of P/E cycles, can influence the lifespan of the drive.

Table 2-4 Endurance Specifications

Capacity	TeraBytes Written
256 MB	3
512 MB	6
1 GB	12
2 GB	24
4 GB	49
8 GB	98
16 GB	196
32 GB	383

Notes:

- The measurement assumes the data written to the SSD for test is under a typical and constant rate.
- The measurement follows the standard metric: 1 TB (Terabyte) = 1,000 GB.

2.6 DC Power Supply

Table 2-5 DC Power Supply

Symbol	Parameter	Min.	Typ.	Max.	Unit
V _{DD}	Power Supply Voltage	2.7	3.3	3.6	V

2.7 Power Consumption

Table 2-6 Power Consumption

Mode	Value	Unit	Condition
Standby	110	μA	Typical
Read	45	mA	Typical
Write	55	mA	Typical

Notes:

- All values are typical and may vary depending on flash configurations or host system settings.
- Active power is an average power measurement performed using CrystalDiskMark with 128KB sequential read/write transfers.

3. Physical Characteristics

3.1 Physical Dimensions

Table 3-1 Mechanical Specifications

Item	Dimensions
Dimensions Card Package	24 mm x 32 mm Min. 23.9 mm x 31.9 mm Max. 24.1 mm x 32.1 mm
Thickness	2.1 mm ± 0.15 mm
Surface	Plain (except contact area)
Edges	Smooth edges

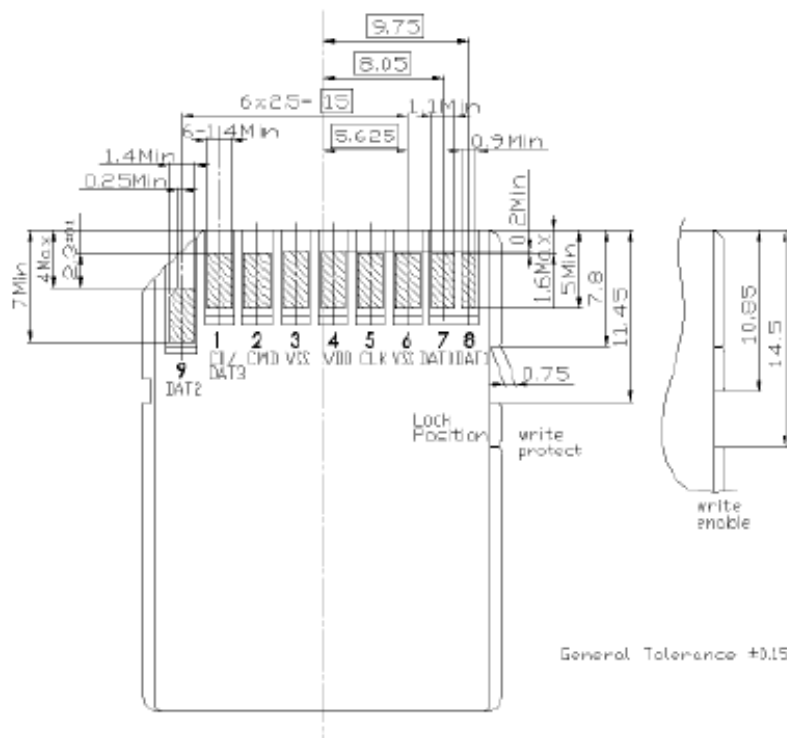

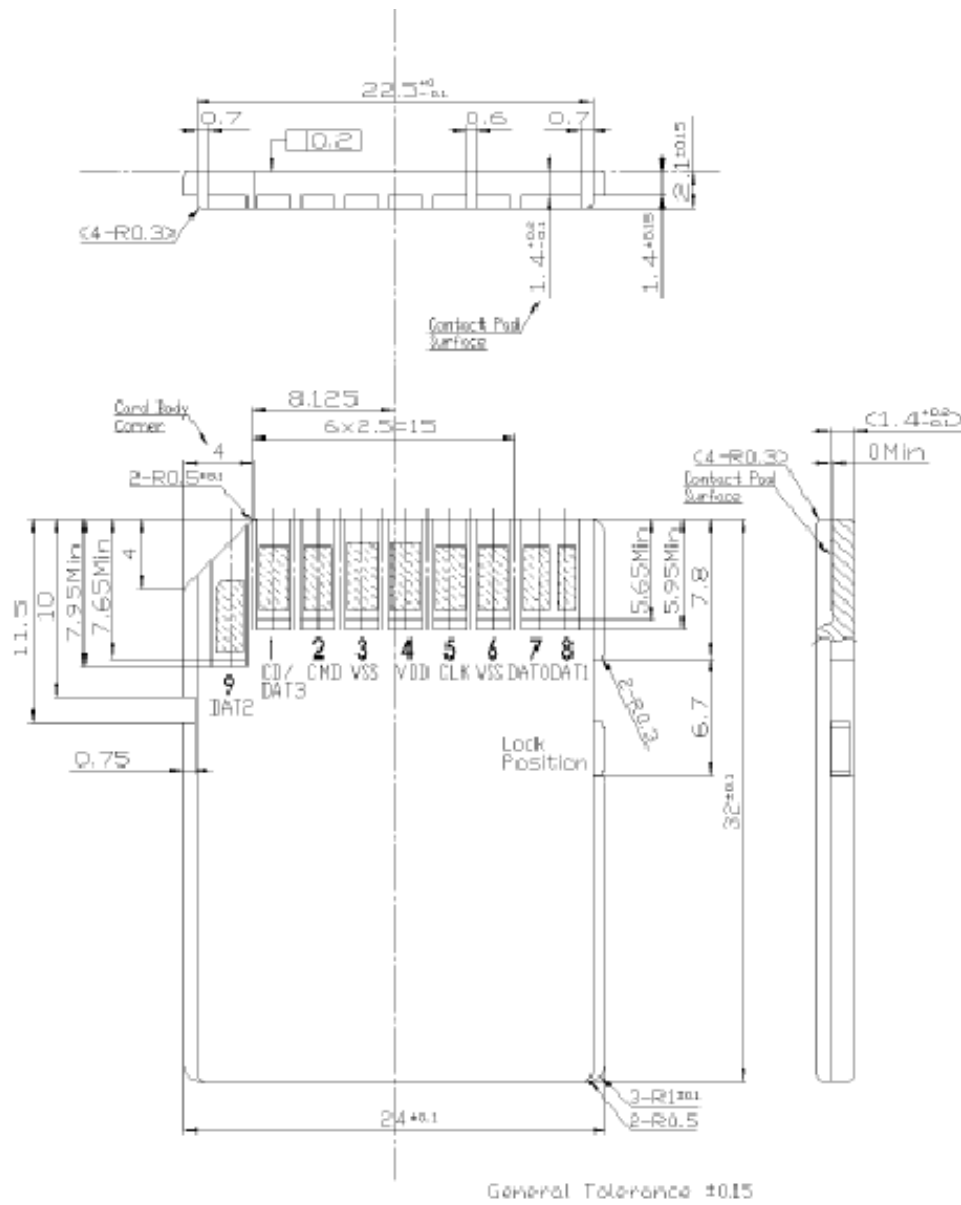

Figure 3-1 Dimensions

3.2 Durability Specifications

Table 3-2 Durability Specifications

Item	Specifications
Temperature	0°C to 70°C (Standard) -40°C to 85°C (Wide)
	-40°C to 100°C (Storage)
Shock	1,500G, 0.5ms
Vibration	20Hz~80Hz/1.52mm (frequency/displacement) 80Hz~2000Hz/20G (frequency/displacement) X, Y, Z axis/60mins each
Drop	1.5m free fall, 6 surfaces of each
Bending	≥ 10N, hold 1min/5times
Torque	0.15N-m or 2.5deg, hold 30 seconds/ 5 times
Salt spray	Concentration: 3% NaCl at 35°C (storage for 24 hours)
Waterproof	JIS IPX7 compliance, Water temperature 25°C Water depth: the lowest point of unit is locating 1000mm below surface (storage for 30 mins)
X-Ray Exposure	0.1 Gy of medium-energy radiation (70 KeV to 140 KeV, cumulative dose per year) to both sides of the card ;storage for 30 mins)
Switch cycle	0.4~0.5N, 1000 times
Durability	10,000 times mating cycle
ESD	Contact: +/-4KV each item 25 times Air: +/-8KV 10 times

4. DC Characteristics

4.1 SD Interface Timing (Default)

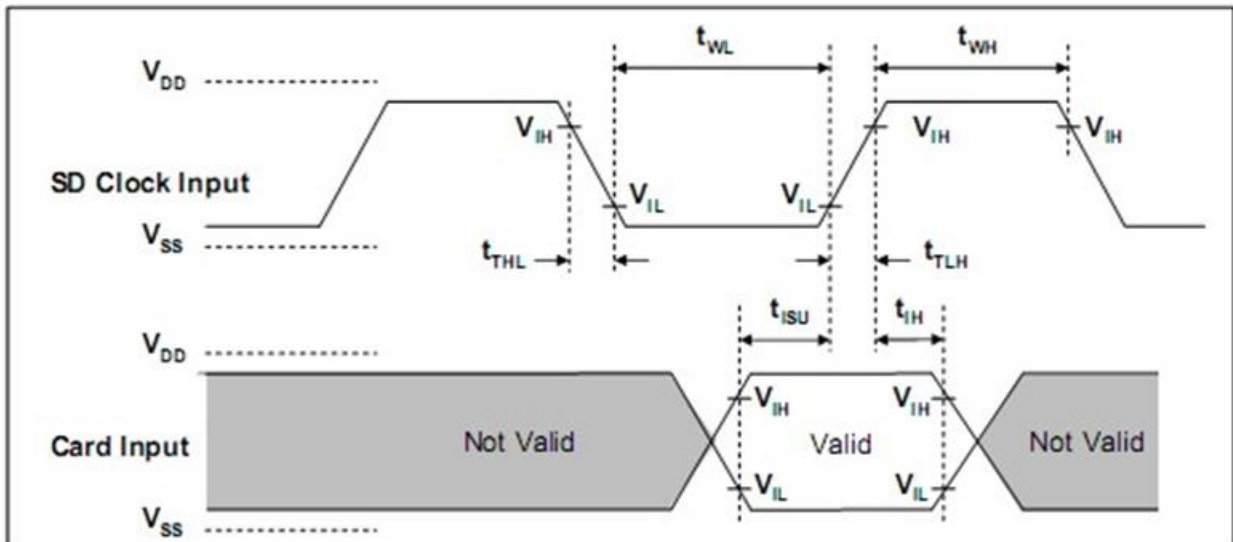

Card input Timing (Default Speed Card)

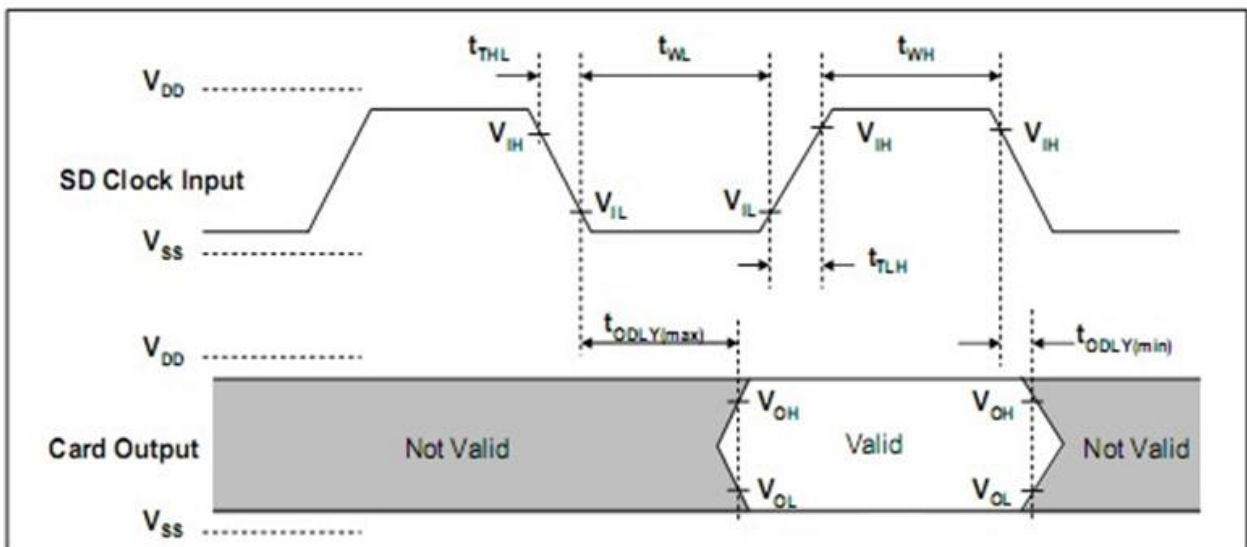

Card Output Timing (Default Speed Mode)

SYMBOL	PARAMETER	MIN	MAX	UNIT	REMARK
Clock CLK (All values are referred to min(V_{IH}) and max(V_{IL}))					
f _{PP}	Clock frequency data transfer	0	25	MHz	C _{card} ≤ 10 pF (1 card)
f _{OD}	Clock frequency identification	0 ⁽¹⁾ /100	400	KHz	C _{card} ≤ 10 pF (1 card)
t _{WL}	Clock low time	10	-	ns	C _{card} ≤ 10 pF (1 card)
t _{WH}	Clock high time	10	-	ns	C _{card} ≤ 10 pF (1 card)
t _{TLH}	Clock rise time	-	10	ns	C _{card} ≤ 10 pF (1 card)
t _{THL}	Clock fall time	-	10	ns	C _{card} ≤ 10 pF (1 card)
Inputs CMD, DAT (Referenced to CLK)					
t _{ISU}	Input setup time	5	-	ns	C _{card} ≤ 10 pF (1 card)
t _{IH}	Input hold time	5	-	ns	C _{card} ≤ 10 pF (1 card)
Outputs CMD, DAT (Referenced to CLK)					
t _{ODLY}	Output delay time during data transfer mode	0	14	ns	C _L ≤ 40 pF (1 card)
t _{OH}	Output hold time	0	50	ns	C _L ≤ 40 pF (1 card)

(1)0Hz means to stop the clock. The given minimum frequency range is for cases that require the clock to be continued.

4.2 SD Interface Timing (High Speed Mode)

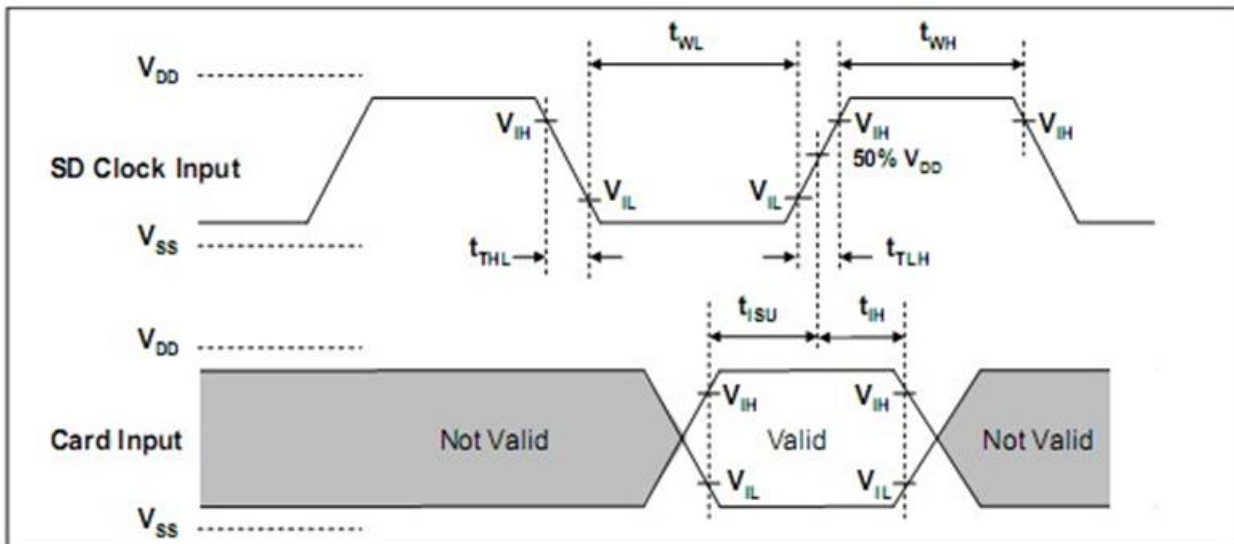

Card Input Timing (High Speed Card)

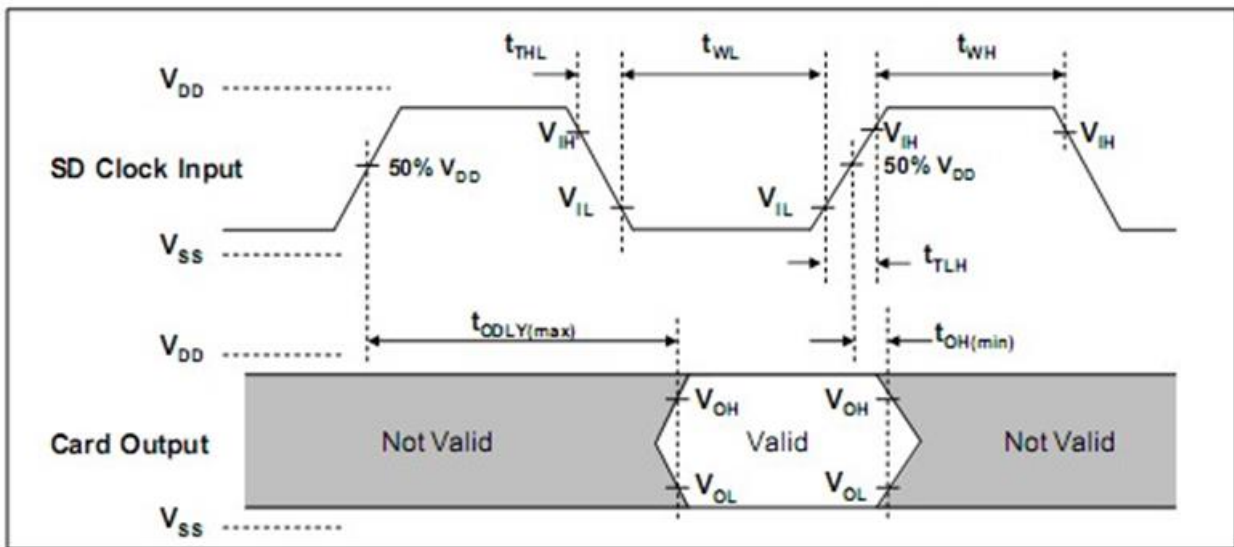

Card Output Timing (High Speed Mode)

SYMBOL	PARAMETER	MIN	MAX	UNIT	REMARK
Clock CLK (All values are referred to min(V_{IH}) and max(V_{IL}))					
f _{PP}	Clock frequency data transfer	0	50	MHz	C _{card} ≤ 10 pF (1 card)
t _{WL}	Clock low time	7	-	ns	C _{card} ≤ 10 pF (1 card)
t _{WH}	Clock high time	7	-	ns	C _{card} ≤ 10 pF (1 card)
t _{TLH}	Clock rise time	-	3	ns	C _{card} ≤ 10 pF (1 card)
t _{THL}	Clock fall time	-	3	ns	C _{card} ≤ 10 pF (1 card)
Inputs CMD, DAT (Referenced to CLK)					
t _{ISU}	Input setup time	6	-	ns	C _{card} ≤ 10 pF (1 card)
t _{IH}	Input hold time	2	-	ns	C _{card} ≤ 10 pF (1 card)
Outputs CMD, DAT (Referenced to CLK)					
t _{ODLY}	Output delay time during data transfer made	-	14	ns	CL ≤ 40 pF (1 card)
t _{OH}	Output hold time	2.5	-	ns	CL ≥ 15 pF (1 card)
C _L	Total system capacitance for each line*	-	40	pF	1 card

*In order to satisfy severe timing, host shall run on only one card

4.3 SD Interface Timing (SDR12, SDR25, SDR50 and SDR104 Modes) Input

4.3.1 Clock Timing

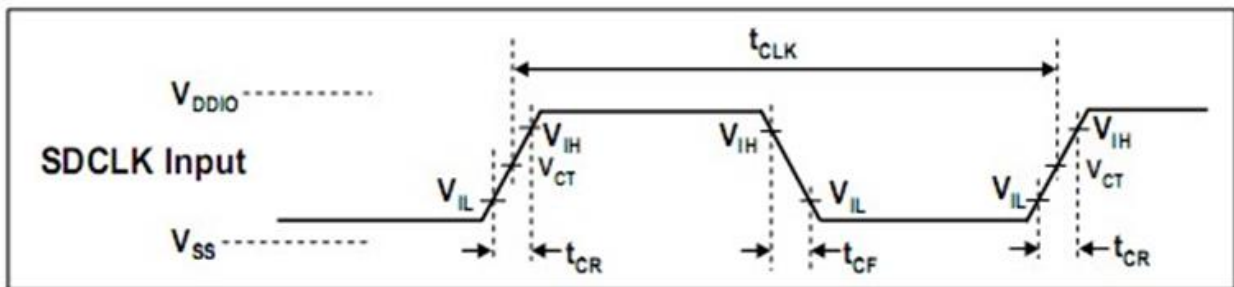

Clock Signal Timing

SYMBOL	MIN	MAX	UNIT	REMARK
t _{CLK}	4.8	-	ns	208MHz (Max.), Between rising edge, V _{CT} = 0.975V
t _{CR} , t _{CF}	-	0.2* t _{CLK}	ns	t _{CR} , t _{CF} < 2.00ns (max.) at 208MHz, C _{CARD} =10pF t _{CR} , t _{CF} < 2.00ns (max.) at 100MHz, C _{CARD} =10pF The absolute maximum value of t _{CR} , t _{CF} is 10ns regardless of clock frequency.
Clock Duty	30	70	%	

4.3.2 Card Input Timing

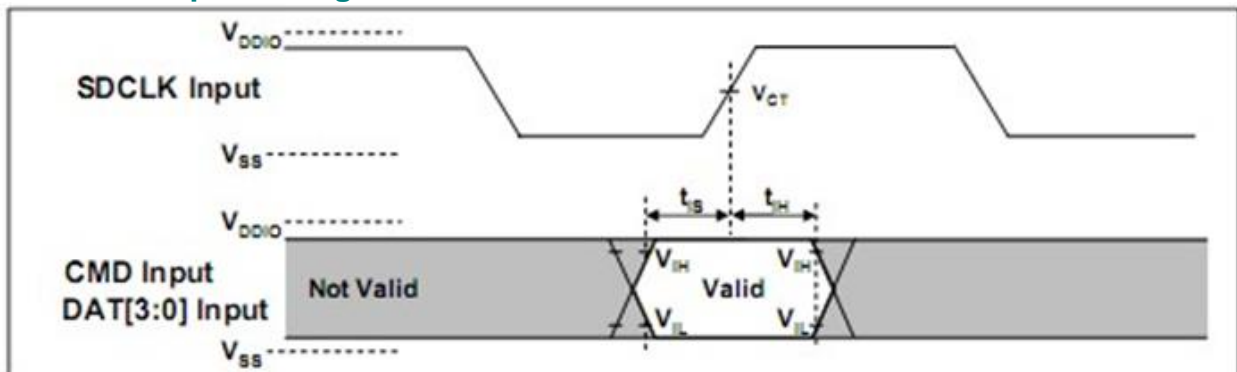

Card Input Timing

SYMBOL	MIN	MAX	UNIT	SDR104 MODE
t _S	1.40	-	ns	C _{CARD} = 10pF, V _{CT} = 0.975V
t _H	0.80	-	ns	C _{CARD} = 5pF, V _{CT} = 0.975V
SYMBOL	MIN	MAX	UNIT	SDR12, SDR25 and SDR50 MODES
t _S	3.00	-	ns	C _{CARD} = 10pF, V _{CT} = 0.975V
t _H	0.80	-	ns	C _{CARD} = 5pF, V _{CT} = 0.975V

4.3.3 Card Output Timing of Fixed Data Window (SDR12, SDR25 and SDR50)

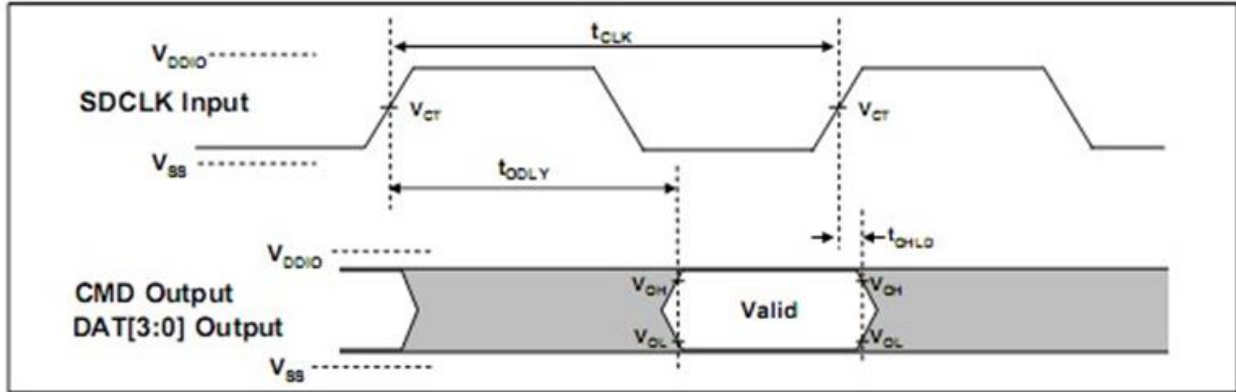

Output Timing of Fixed Date Window⁺

SYMBOL	MIN	MAX	UNIT	REMARK
t_{ODLY}	-	7.5	ns	$t_{CLK} \geq 10.0\text{ns}$, $CL=30\text{pF}$, using driver Type B, for SDR50.
t_{ODLY}	-	14	ns	$t_{CLK} \geq 20.0\text{ns}$, $CL=40\text{pF}$, using driver Type B, for SDR25 and SDR12.
t_{OH}	1.5	-	ns	Hold time at the t_{ODLY} (min.). $CL=15\text{pF}$

4.3.4 Output Timing of Variable Window (SDR104)

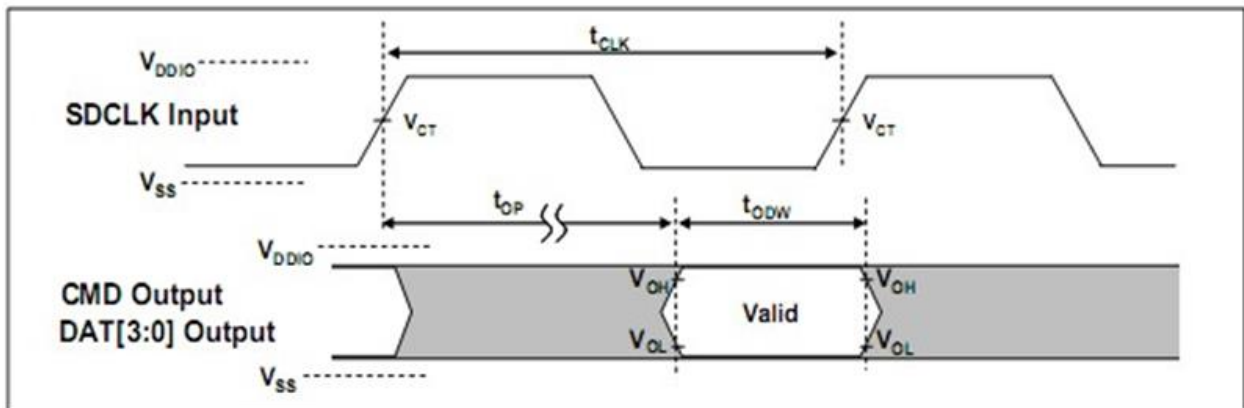

Output Timing of Variable Data Window⁺

SYMBOL	MIN	MAX	UNIT	REMARK
t_{OP}	-	2	UI	Card Output Phase
Δt_{OP}	-350	+1550	ps	Delay variation due to temperature change after tuning
t_{ODW}	0.60	-	UI	$t_{ODW} = 2.88\text{ns}$ at 208MHz

4.3.5 SD Interface Timing (DDR50 Mode)

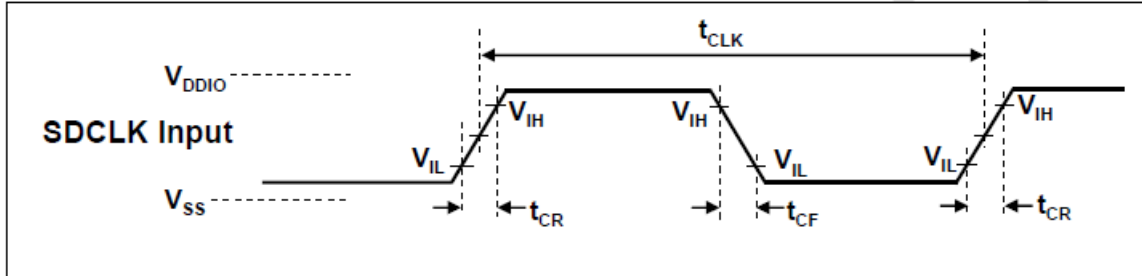

Clock Signal Timing

SYMBOL	MIN	MAX	UNIT	REMARK
t_{CLK}	20	-	ns	50MHz (Max.), Between rising edge
t_{CR}, t_{CF}	-	$0.2 * t_{CLK}$	ns	$t_{CR}, t_{CF} < 4.00ns$ (max.) at 50MHz, CCARD=10pF
Clock Duty	45	55	%	

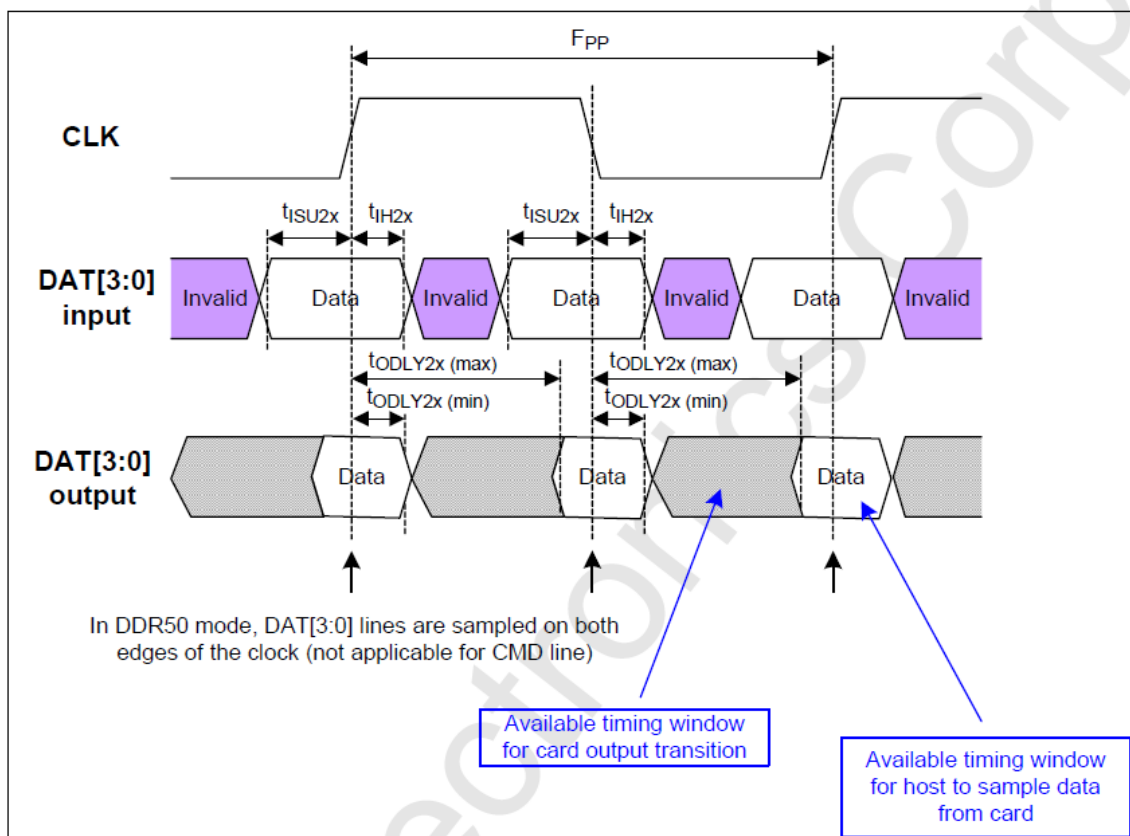

Timing Diagram DAT Inputs/Outputs Referenced to CLK in DDR50 Mode

4.3.6 Bus Timings – Parameters Values (DDR50 Mode)

Symbol	Parameters	Min	Max	Unit	Remark
Input CMD (referenced to CLK rising edge)					
t _{ISU}	Input set-up time	6	-	ns	C _{card} ≤ 10 pF (1 card)
t _{IH}	Input hold time	0.8	-	ns	C _{card} ≤ 10 pF (1 card)
Output CMD (referenced to CLK rising edge)					
t _{ODLY}	Output Delay time during Data Transfer Mode	-	13.7	ns	C _L ≤ 30 pF (1 card)
T _{OH}	Output Hold time	1.5	-	ns	C _L ≥ 15 pF (1 card)
Inputs DAT (referenced to CLK rising and falling edges)					
t _{ISU2x}	Input set-up time	3	-	ns	C _{card} ≤ 10 pF (1 card)
t _{IH2x}	Input hold time	0.8	-	ns	C _{card} ≤ 10 pF (1 card)
Outputs DAT (referenced to CLK rising and falling edges)					
t _{ODLY2x}	Output Delay time during Data Transfer Mode	-	7.0	ns	C _L ≤ 25 pF (1 card)
T _{OH2x}	Output Hold time	1.5	-	ns	C _L ≥ 15 pF (1 card)

5. Product Ordering Information

Apacer's SD card is available in different configurations and densities. See the chart below for a comprehensive list of options for the SD card series devices.

5.1 Product Code Designations

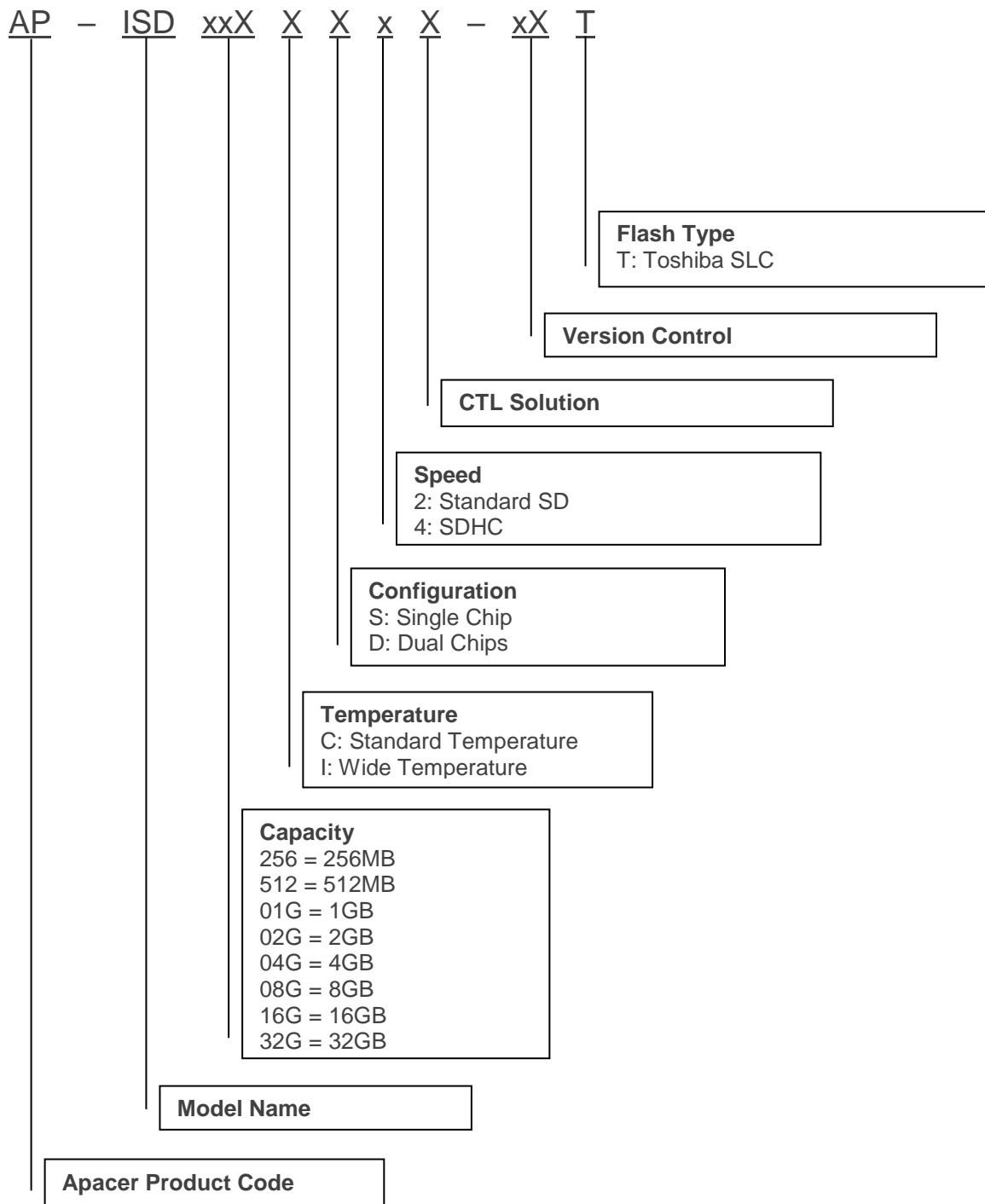

5.2 Valid Combinations

The following table lists the available models of the SD card series which are in mass production or will be in mass production. Consult your Apacer sales representative to confirm availability of valid combinations and to determine availability of new combinations.

Capacity	Standard Temperature	Wide Temperature
256 MB	AP-ISD256MCC-1AT	AP-ISD256MIC-1AT
512 MB	AP-ISD512CS2A-8T	AP-ISD512IS2B-8T
1 GB	AP-ISD01GCS2A-8T	AP-ISD01GIS2B-8T
2 GB	AP-ISD02GCS2A-8T	AP-ISD02GIS2B-8T
4 GB	AP-ISD04GCS4A-8T	AP-ISD04GIS4B-8T
8 GB	AP-ISD08GCD4A-8T	AP-ISD08GID4B-8T
16 GB	AP-ISD16GCD4A-8T	AP-ISD16GID4B-8T
32 GB	AP-ISD32GCD4A-8T	AP-ISD32GID4B-8T

Revision History

Revision	Description	Date
1.0	Official release	2/25/2017
1.1	Added endurance rating for 32GB at Endurance on Specifications Overview and 2.5 Endurance	4/19/2018
1.2	Updated 5.1 Product Code Designations by changing version control code and 5.2 Valid Combinations by changing valid combination for 256MB	3/2/2022

Global Presence

Taiwan (Headquarters)

Apacer Technology Inc.

1F., No.32, Zhongcheng Rd., Tucheng Dist.,
New Taipei City 236, Taiwan R.O.C.
Tel: 886-2-2267-8000
Fax: 886-2-2267-2261
amtsales@apacer.com

U.S.A.

Apacer Memory America, Inc.

46732 Lakeview Blvd., Fremont, CA 94538
Tel: 1-408-518-8699
Fax: 1-510-249-9551
sa@apacerus.com

Japan

Apacer Technology Corp.

6F, Daiyontamachi Bldg., 2-17-12, Shibaura, Minato-Ku,
Tokyo, 108-0023, Japan
Tel: 81-3-5419-2668
Fax: 81-3-5419-0018
jpservices@apacer.com

Europe

Apacer Technology B.V.

Science Park Eindhoven 5051 5692 EB Son,
The Netherlands
Tel: 31-40-267-0000
Fax: 31-40-290-0686
sales@apacer.nl

China

Apacer Electronic (Shanghai) Co., Ltd

Room D, 22/FL, No.2, Lane 600, JieyunPlaza,
Tianshan RD, Shanghai, 200051, China
Tel: 86-21-6228-9939
Fax: 86-21-6228-9936
sales@apacer.com.cn

India

Apacer Technologies Pvt Ltd,

Unit No.201, "Brigade Corner", 7th Block
Jayanagar,
Yediyur Circle, Bangalore – 560082, India
Tel: 91-80-4152-9061
Fax: 91-80-4170-0215
sales_india@apacer.com